

USER'S MANUAL FOR TANK ROTATOR



PREFACE

Thanks for purchasing our product & looking forward to your precious advice for improvement of our product. We will dedicate to produce the best products and offer the best services.

The machine has been carefully inspected both mechanically and electrically before it left the factory. The machine should be initially inspected upon receipt, if any damage which may have occurred in transit inform “WARPP ENGINEERS PVT.LTD. OR It’s Dealer immediately. Check for the accessories supplied against those listed in packing slip.

Caution: Before attempting to connect the equipment to any Power source, read instructions carefully.

In case any defect or deficiency, contact “WARPP ENGINEERS PVT.LTD.” or its authorized Agent. Make sure to quote model number and serial number of the equipment in all correspondence.

THE DESIGN OF THIS EQUIPMENT IS SUBJECT TO CONTINUOUS DEVELOPMENT AND IMPROVEMENTS, CONSEQUENTLY “WARPP ENGINEERS PVT.LTD.” RESERVES THE RIGHT TO INCORPORATE MINOR CHANGES FROM THE INFORMATION CONTAINED IN THIS MANUAL.

INDEX

1. SAFETY
2. PRODUCT DESCRIPTION & FEATURES
3. WORKING CONDITION & ENVIRONMENT REQUIRED
4. TECHNICAL SPECIFICATION
5. WORKING PRINCIPLE
6. INSTALLATION
7. CONTROLS
8. PARAMETER AND ITS OPERATIONAL MEANING
9. HOW TO OPERATE THE MACHINE
10. Do's & Don'ts
11. WIRING DIAGRAM
12. MAINTENANCE
13. SPARE PART LIST

1. SAFETY

Our machines are designed and built with ample safety considerations. However, proper installation & operation of the machine will increase your safety.

DO NOT INSTALL, OPEARTE OR REPAIR THIS EQIPMENT WITHOUT READING THIS MANUAL

Following points to be taken care while installing the machine

- Ensure that children or animal do not have access to the machinery
- Ensure that the machine is placed properly so that it has enough ventilation and also stability so that it does not fall
- Any safety items fitted, must not be bypassed, or removed. if they have to be removed then the equipment must be put out of operation, until a repair is completed
- Always keep the workplace clean & free from obstacles
- Make sure that the work area is well lit.
- Ensure that the machine is regularly maintained to ensure that it remains safe.
- Electric shock can kill. Please make sure that you follow the below guidelines
- All electrical supply terminals shall be well covered and insulated
- Do not touch both the output terminals with bare hand as it may lead to electric shock
- Always use proper hand gloves and other safety equipment while operating the machine

- Use proper shaded welding screen as the arc has ultra violet rays which can damage the eye sight
- Do not obstruct any moving parts as it may cause harm
- Ensure that the clothing is fire resistant to protect your skin from burns and arc rays
- When compressed gas to be used, then special precautions to be taken to prevent explosion
- Please make sure that no inflammable items are there in the weld area
- Spatters can cause burns ensure that you use all personnel protective equipment
- Newly supplied machines, which is packed in either corrugated box or wooden box shall be shifted using forklift
- Proper care shall be taken while shifting or relocating the machines. Use lifting hooks / mechanism provided on the machine

2. PRODUCT DESCRIPTION & FEATURE

The Conventional Rotator is designed to aid the welding of cylindrical vessels.

A Conventional Welding Rotator consists of two (2) parts:

- A Motorized drive (power) unit; and
- An Idler supporting unit.

The power unit is driven by a heavy duty geared AC motor which is designed according to internationally proven specifications to ensure constant speed.

The heavy-duty Wheels are Coated with Poly urethane coating with a shore hardness of 90. These coatings not only absorb shock during placement of shells but also provide required friction for proper rotation of the job. These coating are also required when SS jobs are welded as contact of these metal with CS wheel result in carbon inclusion.

By using independent drive & idler units, vessels of varying lengths can be placed on the Rotators supported on the Rotator wheels. The wheel can be adjusted on the base frame to accommodate different vessel diameter.

Tank Rotators are usually arranged in sets including a pair of identical rolls, one of the which is rotated by an electric motor through a reduction gearbox, known as powered unit or drive unit while the other is idler, so arranged that the distance between the rolls can be adjusted to accommodate vessels of different diameters.

The idler unit basically consist of a base frame with two-wheel bracket bolted on to the top of it. there are holes drilled through the top of the base frame so that the wheel brackets can be positioned at different distances apart, to suit the vessel diameter.

The drive unit again has two-wheel brackets and similar to the idler unit these can be positioned to suit the vessel diameter. Both wheel brackets are motorized.

Note

Self-Centered Rotators will have a lead screw and a hand wheel .the distance between the two rollers can be adjusted by turning the hand wheel provided on drive/idler unit.

3.Working condition & Environment **Required**

Please make sure that there is enough space around the drive & idler unit of tank Rotator so that servicing can be carried out.

- 1) Please note that this equipment to be installed in a clean place free from dirt, moisture
- 2) Avoid direct exposure to sunlight
- 3) Care should be taken to see that it is not exposed to rain
- 4) Whenever the machine to be used at a site make sure proper shade is provided for the machine
- 5) Do not keep the machine near oven, furnace where temperature may be higher and it can affect the performance of the machine
- 6) Always keep the machines at lease with a gap of 300 mm around the machine as it is required for free circulation of air
- 7) Keep the machine in a flat position
- 8) Use cables with proper cross section based on the input power requirement of the machine (Please refer to technical specification page for input power of the machine)

9) When long cables are used you need to select higher cross-sectional area of conductors to avoid voltage drop during the usage.

Selection guide for type of MCB

MCB Type	Tripping Current	Application
B Type	3 to 5 times the rated current	Purely resistive load like lighting and general-purpose outlets
C Type	5 to 10 times the rated current	Moderate inductive load like air conditioners, residential / commercial pumps
D Type	10 to 20 times the rated current	Heavy inductive loads like heavy induction motor and welding machines

Selection of cable size for input supply

Please note that the cable size required for input supply depends on following

- 1) Whether the machine is single phase or three phases
- 2) Input KVA of the machine
- 3) Distance from electrical supply point

First calculate the current the machine will draw based on the input KVA given (refer to technical specification page for this)

If the machine is a single-phase machine then each KVA would require around 4.6 Amps of current. That means if input KVA of the machine is 5 KVA, then it would draw 23 Amps at full load

If the machine is a three-phase machine then each KVA would require around 1.4 Amps of current. That means if the input KVA of the machine is 5 KVA, then it would draw around 7 amps of current at full load

Cable capacity for copper cable can be taken as 5 Amps / Sq mm when cable length is less than 10 meters. That means 1 sq mm cable can carry a current of 6 Amps of current

Now you have
input current of the machine based on its input KVA

You can calculate the conductor size by this formula

Input current / capacity of conductor

Example

From the above for a single-phase machine of 5 KVA you would need $23/6=3.8$ Sq mm cable. (You can choose 4 sq mm cable)

From the above for a three-phase machine of 5 KVA you would need $7/6=1.16$ Sq mm cable. (You can choose 1.5 sq mm core cable for each phase)

Note:

When the length of the cable is short the required cross section for input cable will come down

Below table will help you in selecting the right size of welding cable based on the length and current to be used.

Welding Cable selection chart					
Welding Current in Amps	Recommended Cable size (Sq mm) based on length (in Mtrs)				
	1 ~ 15 Mtrs	15 ~ 30 Mtrs	30 ~ 45 Mtrs	45 ~ 60 Mtrs	60 ~ 75 Mtrs
100	16	25	25	35	50
150	16	25	35	50	50
200	35	35	50	50	70
300	50	50	70	70	95
400	70	70	70	95	120
600	95	95	95		
800	140	140			
1000	140	190			
1200	190	240			
1500	240	285			

Note:

Table given is just for reference and the actual result may vary depending on the quality of conductor

Multiple cables can be used where every single cable of that capacity is not available

4. TECHNICAL SPECIFICATION

MODEL	LOAD CAPACITY	WHEEL DIA(MM)	WORK PEICE DIA(MM)	WHEEL WIDTH (MM)
KT-2	2	200	200-1200	100
KT-5	5	250	250-2300	100
KT-10	10	300	300-2800	120
KT-20	20	300	500-3500	120
KT-30	30	400	600-4200	150
KT-40	40	400	700-4600	150
KT-50	50	500	750-4800	150
KT-60	60	500	800-5000	150

- NO. OF WHEELS - 4
- WHEEL SPEED - 0.8 TO 0.16 MTRS/MIN
- INPUT POWER- 3 PHASE 380-440 VOLT 50 HZ SUPPLY
- WHEEL MATERIAL - RUBBER/POLYURATHANE +C.I. STEEL

5. WORKING PRINCIPLE

Tank Rotators are usually arranged in sets including a pair of identical rolls, one of the which is rotated by an electric motor through a reduction gearbox, known as powered unit or drive unit while the other is idler, so arranged that the distance between the rolls can be adjusted to accommodate vessels of different diameters.

The idler unit basically consist of a base frame with two-wheel bracket bolted on to the top of it. there are holes drilled through the top of the base frame so that the wheel brackets can be positioned at different distances apart, to suit the vessel diameter.

The drive unit again has two-wheel brackets and similar to the idler unit these can be positioned to suit the vessel diameter. Both wheel brackets are motorized.

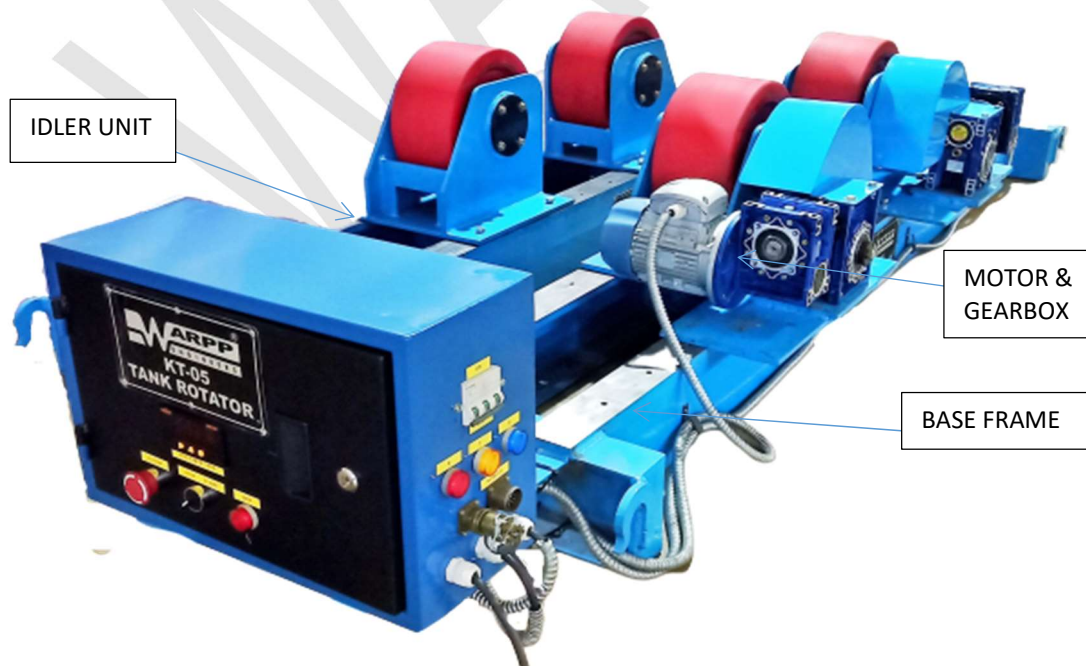



6. INSTALLATION

Once the Rotators are received at your end inspect for proper condition of the equipment then choose the proper place for Rotator installation.

Make sure that enough space is there around the machine. Please note that the vessels will stretch out of the Rotators and you need to allow space for that as well.

Vessels are loaded on to the Rotators by crane and hence make sure that position of the Rotator in under the crane.

Lifting by Crane

The Rotator can be lifted by using the two hooks provided at the end of the chassis. it is desirable that the angle between the chain & the lifting crane should be 60°. (as shown in figure)

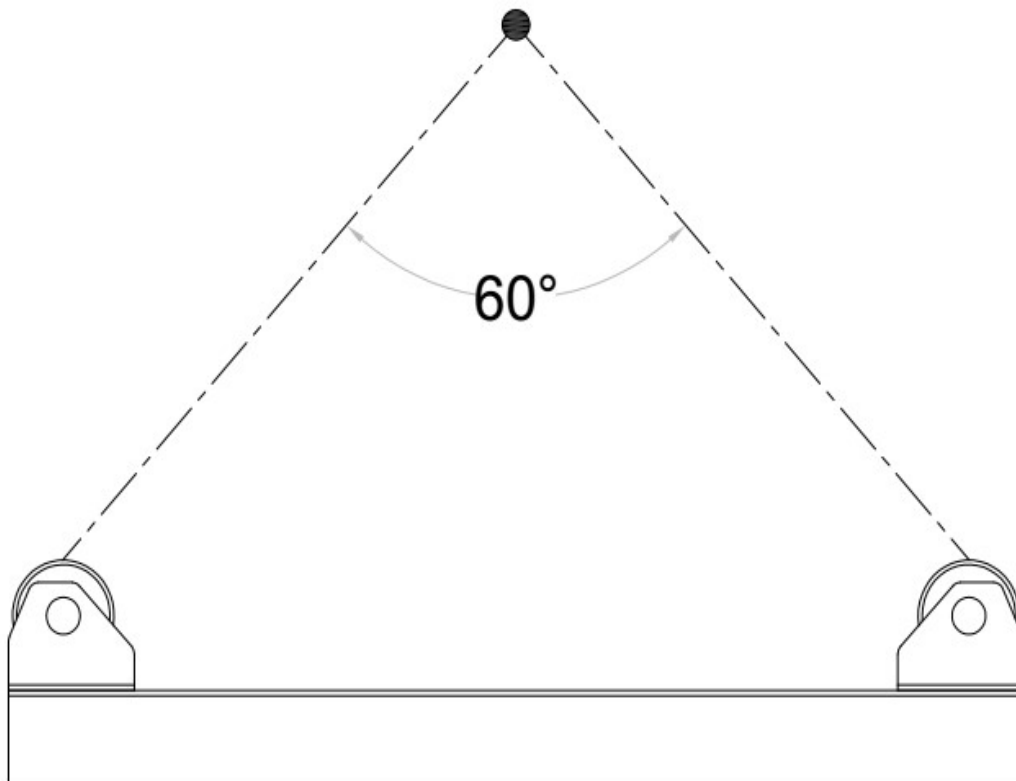

Note

It is important to balance the loading equally between the drive and idler section. Failure to do so may result in overloading one of the sections which will cause problems when trying to rotate the vessel. It can also result in back driving where the vessel can continue to rotate after stopping the Rotators.

ADJUSTING THE WHEEL BRACKET

The operator will need to adjust the position of the two-wheel bracket on the base frame, so that vessels of different diameter can be loaded.

To do this operator needs to;

- Unbolt the wheel bracket from the base frame
- Use a crane (Can be pushed in case of lower capacity rotators) to lift the wheel bracket using the hooks
- Move the wheel bracket to the required position for the diameter of the vessel
- Bolt the wheel bracket back on to the base frame using all the bolts, and tighten properly

INCLUDED ANGLE

The included angle is the angle between two lines from the center of the rotation axis of the vessel to the center of each wheel on the drive or idler section.

The distance between the wheel bracket on both the drive and idler unit depends on the diameter of the vessel. the included angle should be between 45° to 60°.

Note - in case of self-centering Rotators the wheel distance can be adjusted by turning the hand wheel. Do not turn the hand wheel with job loaded on the Rotators.

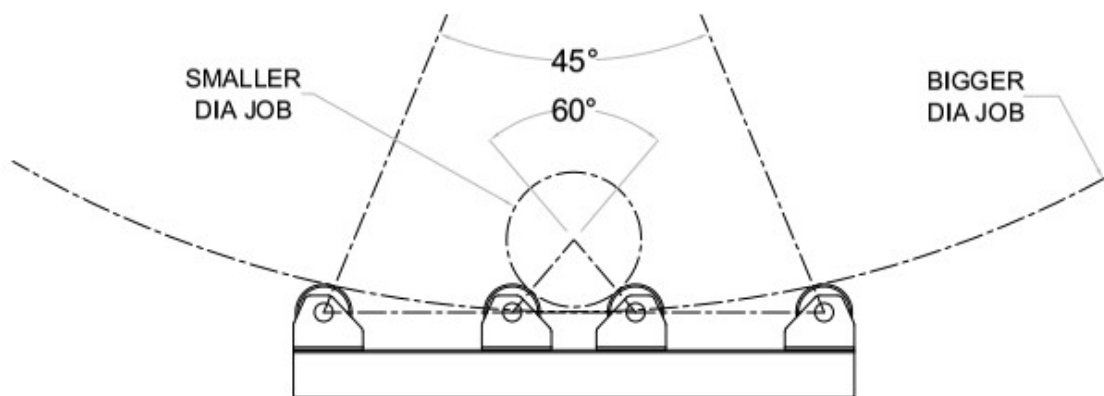

It is important, as the angle increases so does the resulting load on each wheel, and consequently the load on the bearings. Increased inclusive angle also demands more torque, and therefore more power is required to rotate the vessel.

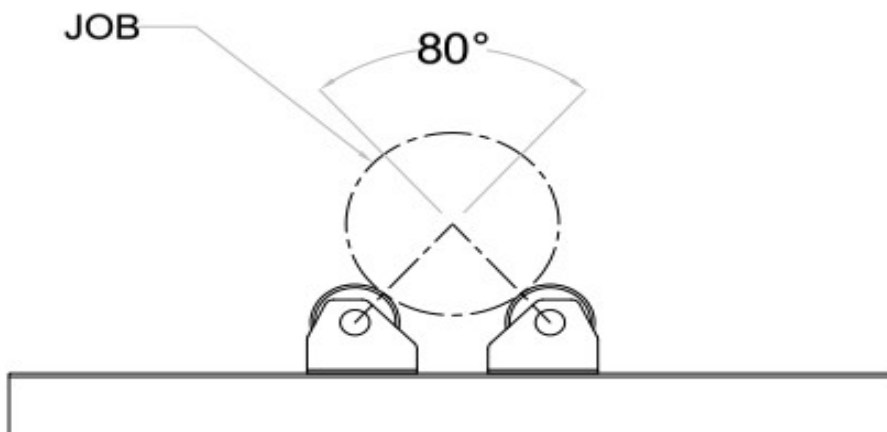

ONLY USE 80° ANGLE UPTO 60% OF LOAD CAPACITY JOB.

7.CONTROLS

REMOTE

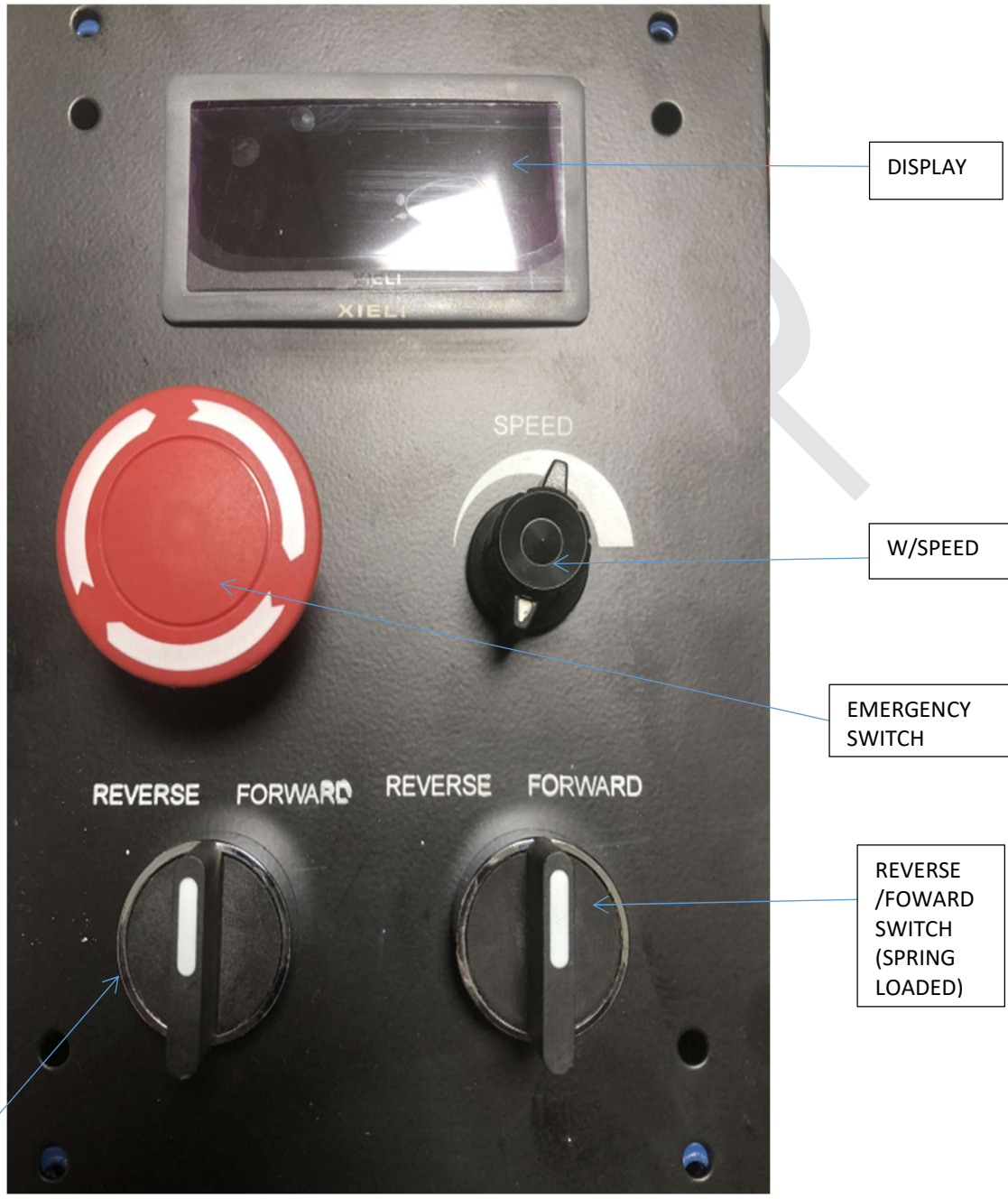

DISPLAY

W/SPEED

EMERGENCY
SWITCH

REVERSE
/FOWARD
SWITCH
(SPRING
LOADED)

REVERSE/
FORWARD
SPEED

8 . PARAMETER & ITS OPERATIONAL MEANING

W/SPEED	This indicator will show the speed of the wheel in RPM or Linear Speed of the wheel. This speed OR RPM is the speed/RPM of the job also
E STOP	This is an emergency STOP button
SPEED	This knob is used for step-less regulation of the speed of the wheels of drive unit
FORWARD / REVERSE SWITCH (Left)	This Switch is used to set the direction of rotation for the wheel
FORWARD / REVERSE SWITCH (Right)	This is a spring return switch used as inch Switch for momentary rotation of the wheel.

9. HOW TO OPERATE THE MACHINE

- First complete the installation as explained in chapter 6
- Set the wheel housing on scale as per your job diameter.
- Load the job on the Rotator wheels with the help of crane.
- Turn on the main supply and also the MCB provided on the machine.
- Set the required current as per electrode size and job thickness (As per WPS)
- Set the speed of job with the help of speed knob provided on remote box.
- Start the welding process
- Start the Rotator.

10. DO'S & DON'TS

- **Don'ts** -Welded or extended Parts of vessel may come into contact with the Rotator frame, Wheel OR the floor Resulting in damage to Rotator or toppling of the job. This may also result in over load of the Rotator.

Do's -Care should be taken while loading a job on Rotator. Please make sure extended parts of job do not touch the ground or Rotator frame base. If there are extended parts on job; keep the Rotator on height so that it will not touch the ground.

- **Don'ts** - If distance between the wheel bracket is too large, thus demanding more torque for the vessel of same weight.

Do's - Always maintain the proper distance between the wheel bracket as per the job diameter.

- **Don'ts** - If Wheel brackets are too close together. this is very unsafe position. During rotation the vessel could roll of the Rotator causing very serious injury to anyone in the vicinity of the Rotators.it can also happen if there is an out of balance load I.e., the center of gravity of the vessel is offset from the axis of rotation. The Rotators should never be operated at an angle less than 45°

Do's - when you load the job on rotator wheels; please make sure you maintain angle between 45° to 70° between the wheel center

- **Don'ts** - If the drive unit & idler unit are not parallel to each other than the vessel can creep lengthways and even fall off the Rotators. This can cause wear and damage to the

wheels of the Rotator. See figure below for correct alignment detail

Do's - Always keep drive unit & Idler unit parallel to each other.

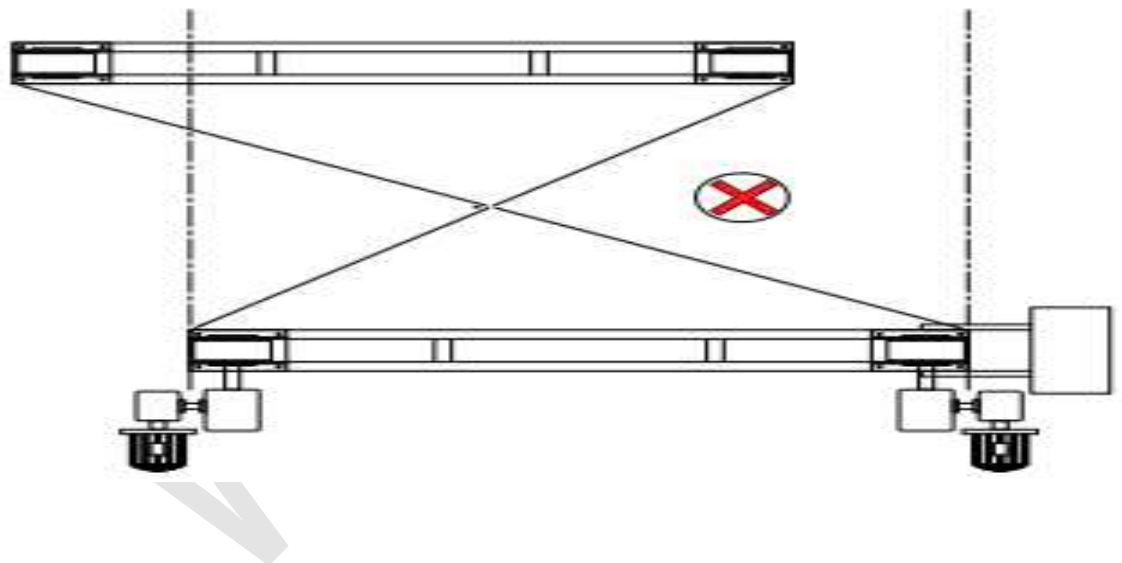
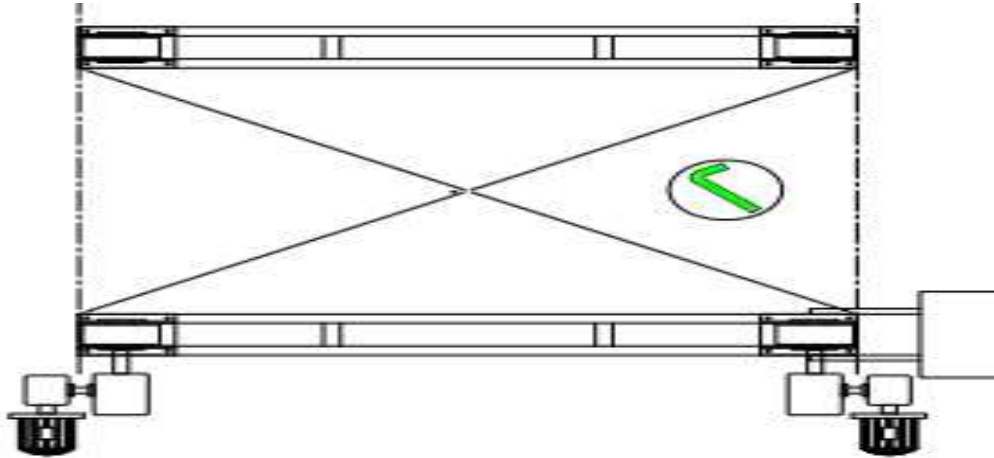

- **Don'ts** - Ensure that units are not tilted as well as heights are within limits.

Please refer following diagram for better understanding.

Do's - Both the drive unit and idler unit should be placed on flat surface for better performance.

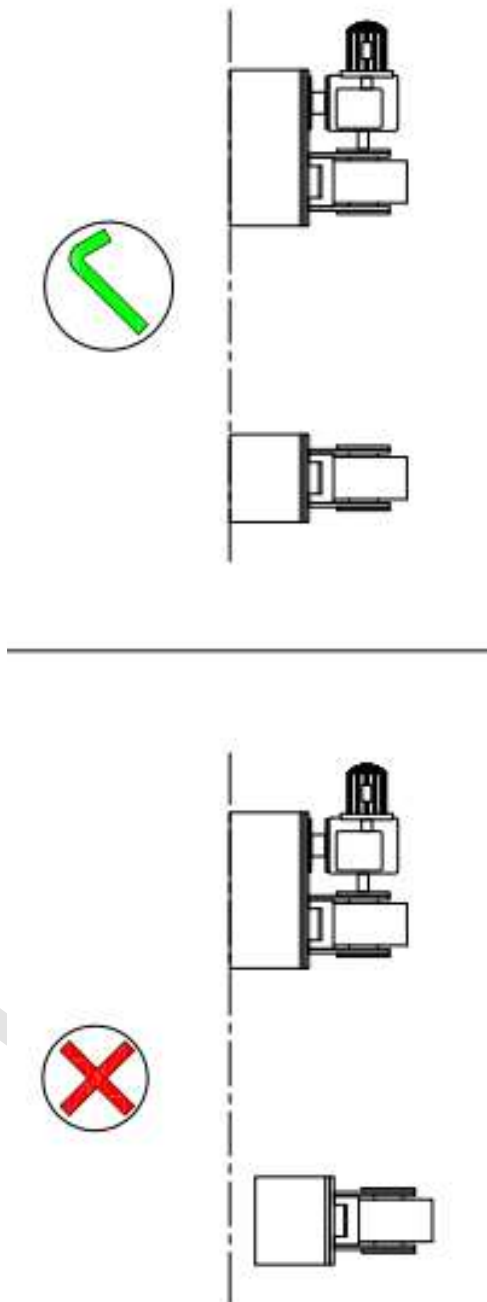

- **Don'ts** - Please do not bolt the drive unit and idler unit wheel bracket on different holes.

Do's - Both the drive unit and idler unit wheel bracket should be bolted on same holes on chassis. (As shown in below fig)

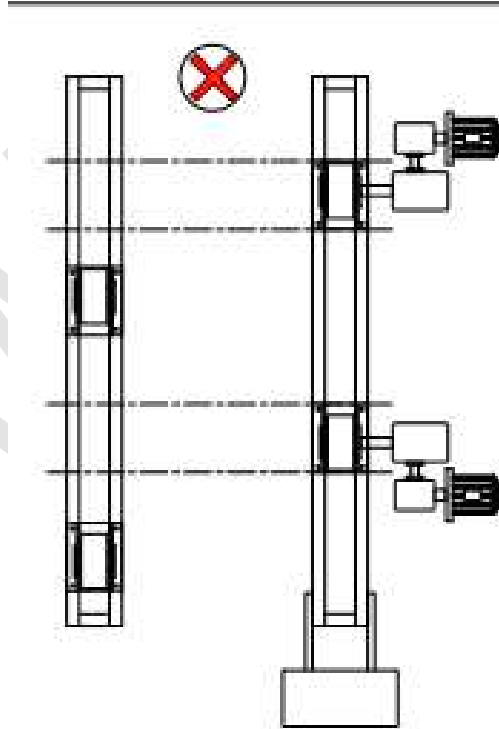
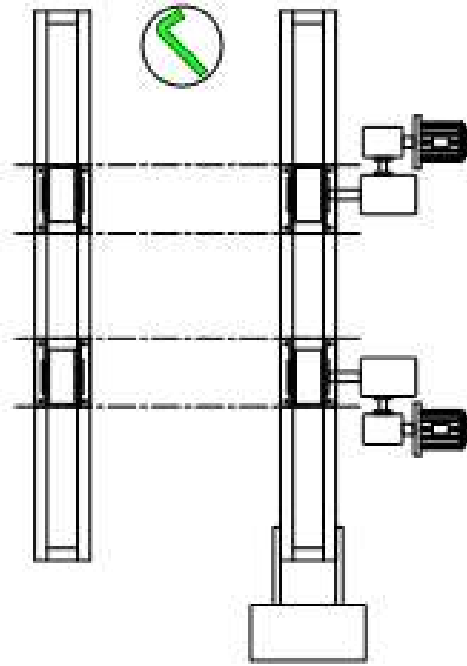

11. WIRING DIAGRAM

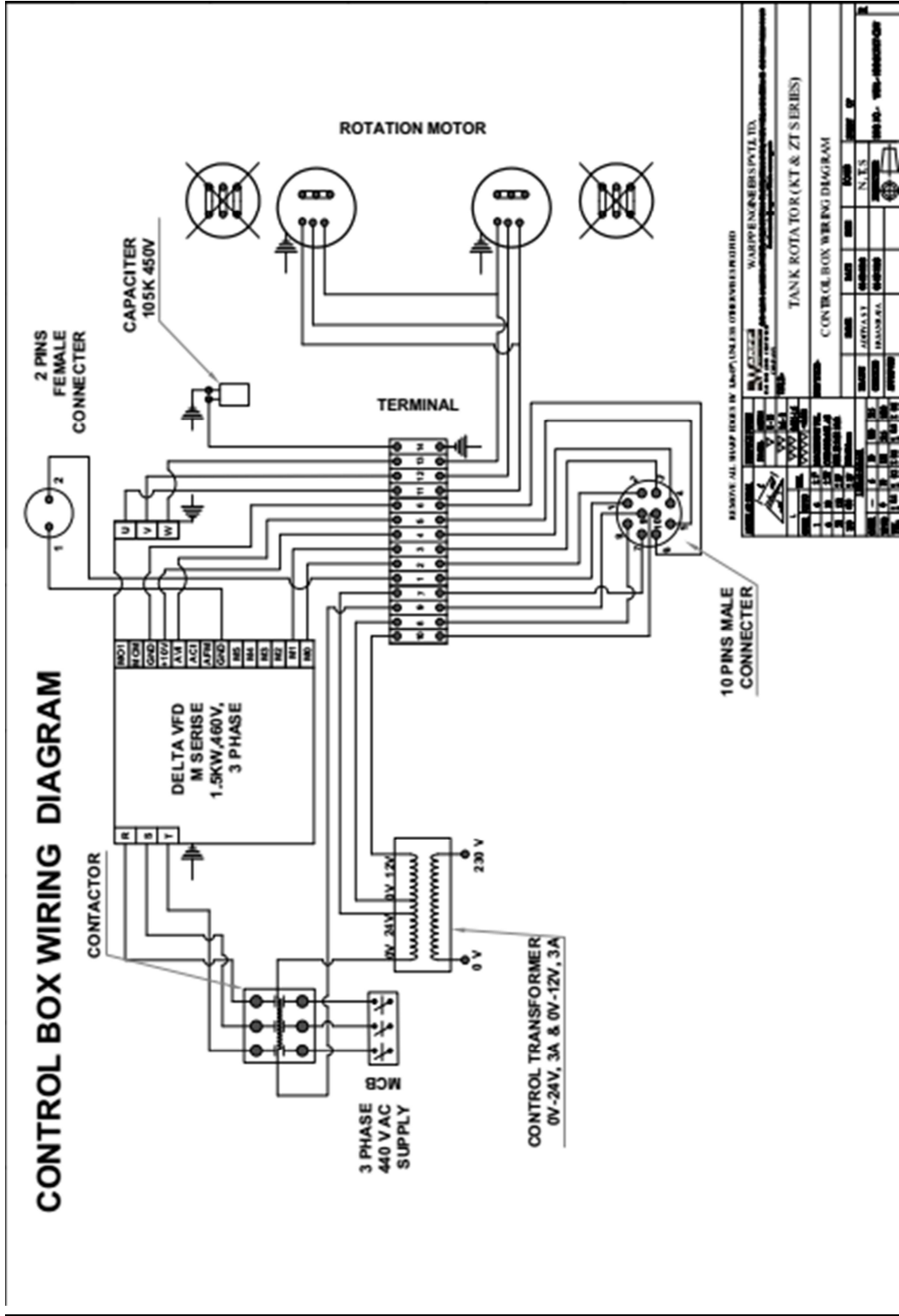

12. MAINTENANCE

During all repair and maintenance and repair procedures, the Rotators must be electrically isolated. Do this by switching off the main supply and unplugging the mains cable.

After disconnecting the power there may be some residual charges in some components in the panel. Wait for few minutes after disconnecting the mains power before commencing work on any electrical elements of the machine.

INSTALLATION

Before starting up , check the following ;

- All moving parts can freely move
- Check oil level in the gearbox
- Check the integrity of all cable, mains and remote box, make sure there are no cuts
- Check the remote box controls all operate correctly
- Check the emergency stop on the remote box is working,

FIRST TIME IN RUN

In order for the worm gearbox to reach its optimal efficiency, when first installed the Rotator should run in both the direction for the following period of time;

- At least 4 hrs. running with no load on Rotators

REPAIR AND MAINTENANCE

To continue the longevity of the equipment, all efforts should be made to keep the Rotators clean and free from dirt or waste from welding process.

Gearbox oil level should be checked regularly and kept at the correct levels.

At least once a in year the whole installation should be inspected with particular attention paid to the following;

- Poor electrical contact
- Switches and controls
- Loose mechanical parts, ensure all fixes are correctly tightened
- Condition of wheel
- Check through rotation of wheel (i.e., no eccentric rotation around the axles.)
- Metal corrosion
- Follow maintenance procedure for the gearbox
- Check all the cables for damage
- Check the emergency stops and also correct functioning of the panel

If there is any excessive damage then the parts should be removed and replaced with new.

13. SPARE PART LIST

Part Name	KT-02	KT-05	KT-10	KT-20	KT-30	KT-40
Chassis	SA00128	SA00148	SA00083	SA00089	SA00102	SA00122
Idler Unit Wheel Assembly	SA00131	SA00150	SA00064	SA00091	SA00106	SA00106
Main Shaft for Idler Unit	SA00139	SA00139	SA00072	SA00072	SA00114	SA00114
Bearing	SP03613	SP03613	SP03614	SP03614	SP00397	SP00397
PU Lining Wheel	SP04210	SP02936	SP02938	SP02938	SP02941	SP02941
Drive Unit Wheel Assembly	SA00141	SA00156	SA00074	SA00091	SA00116	SA00124
Main Shaft for Drive Unit	SA00145	SA00145	SA00078	SA0007	SA0012	SA00120
Motor	SP03325	SP00001	SP00090	SP03327	SP03328	SP03329

ELECTRICAL

SP02857	Power Plug Metal Type 2 Pin (Female) Ms 3102R 14S-9S
SP02858	Power Plug Metal Type 2 Pin (Male) Ms 3106F 14S-9P
SP02861	Power Plug Metal Type: -10 Pin (M) Ms 3102R 18-1P
SP04180	Control Transformor input-415V, Out-Put-10V.1Amp
SP01887	Indicator II12-230Vc Red/Yellow/Blue
SA00082	PLC Card
SP03055	Remote Control Box for Tank Rotator
SP03439	Selector Switch 3 Position Centre Off with Spring Return Both Side
SP02860	Power Plug Metal Type: -10 Pin (F) Ms 3106F 18-1S
SP01983	Knob: -Modle-Ak46
SP02834	Potentiometer-10K Ohn,10 Turn (3590S-2-103L)
SP01103	Digital Panel Meter Current
SP01285	Emergency Stop
SP02598	No Element for Push Button-10A
SP02591	Nc Element for Push Button-10A